

# Façade connection channel JTA-SD

Connection system for metal deck floor slabs

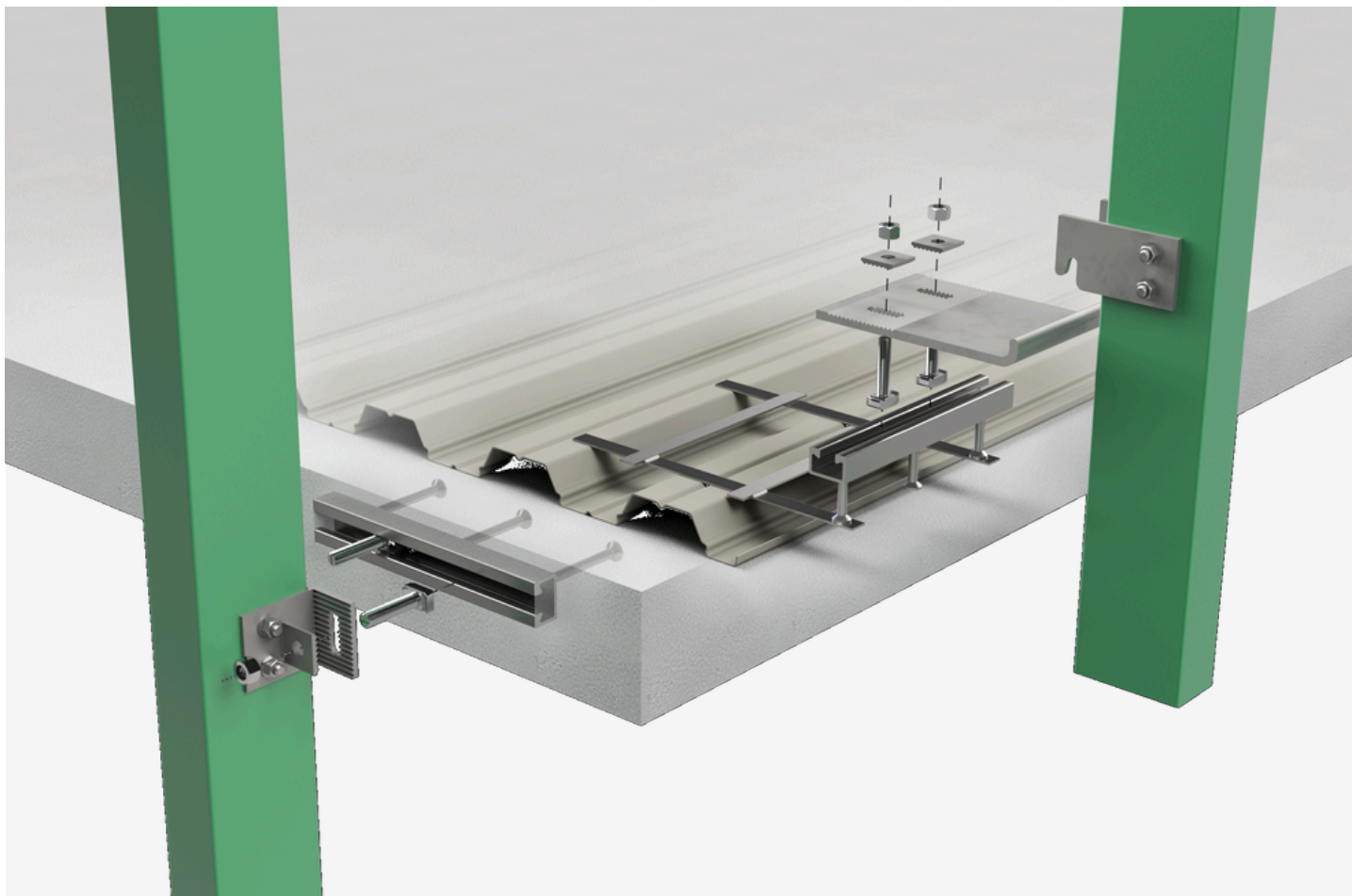

# Façade connection channel JTA-SD

## Simple, accurate and adjustable connections to the top of composite metal deck floor slabs.

The façade connection channel JTA SD is individually designed to meet the specific project needs of customers who want to connect facades or other building components to the top face of a composite metal deck floor slab. It is an engineered product based on our anchor channel technology that provides reliable transfer of loads into the floor slab.

Modern metal deck floor slabs have a wide range of variables in their design. These include concrete strength, reinforcement dimensions and positions, slab thickness, and metal deck dimensions. There is also a large range of variations in the required input loads that need to be supported. Consequently, these conditions combine to create a requirement for a very versatile connection system. The façade connection channel JTA SD provides this versatility and has proven its reliability on hundreds of projects.

In addition to reliable performance, the façade connection channel JTA SD is also simple to install. This makes the product very popular among contractors who face the difficulty of accurately positioning connections. Before the concrete is poured the product is securely connected to the lower metal formwork with self-drilling screws or rivets.

The height of the unit is designed for each project to match the thickness of the floor slab, enabling fast and easy levelling. Also, by incorporating twist-in T-bolts, the façade connection channel JTA SD enables fast connections that can be adjusted in the JORDAHL channel profile to the correct position.

## Section through composite floor slab:

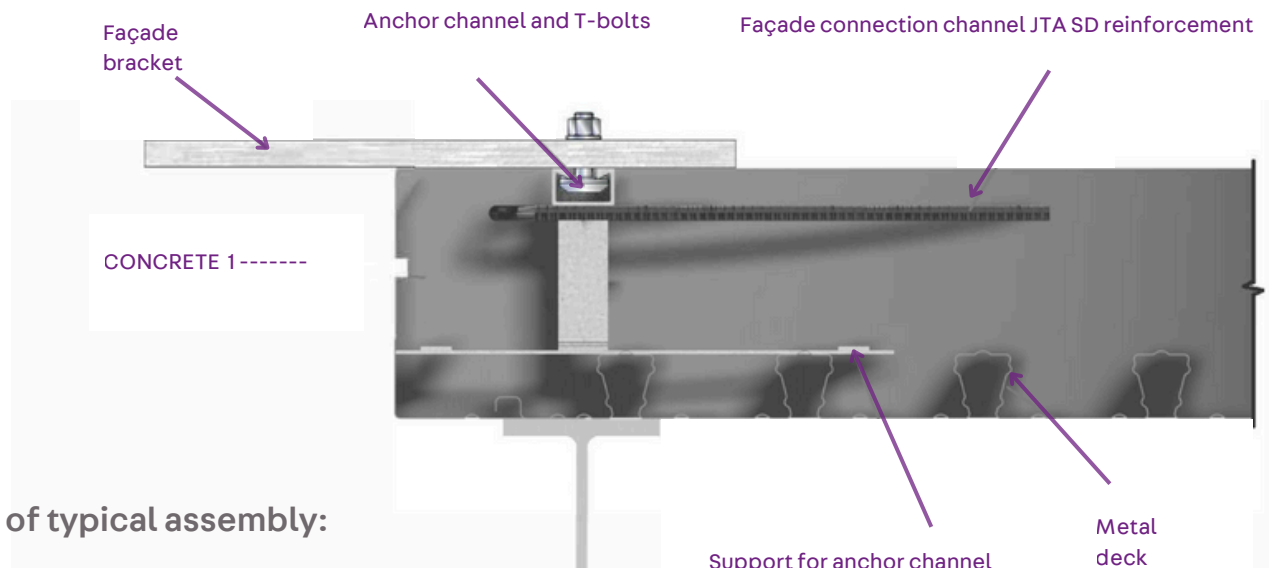

## Isometric of typical assembly:

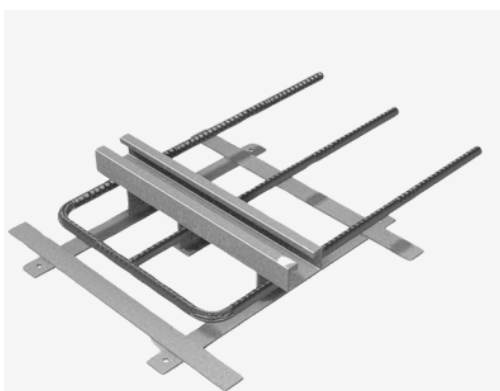

The façade connection channel JTA SD is custom-designed by technical experts on a project basis to distribute applied loads into the physical geometry of the floor slab.

# Façade connection channel JTA-SD

## Typical variations of assemblies:



Double channel variation typically incorporating 4 T-bolts



Extended legs for deeper slabs

## Special variations of assemblies:



Special corner assembly

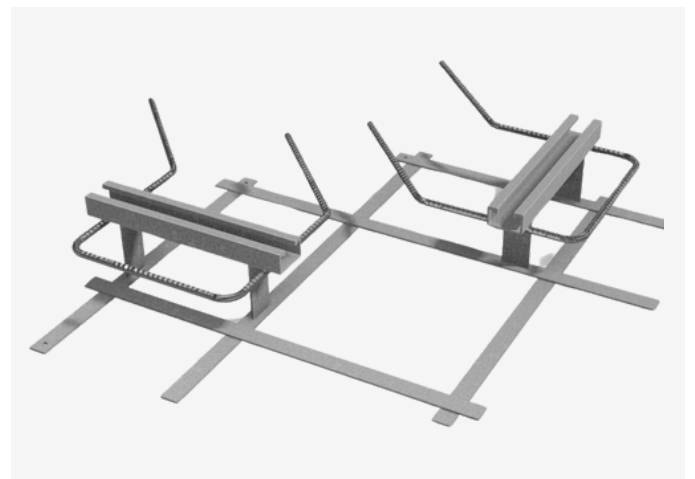

Special reinforcement design

PohlCon UK Limited

Thame Forty  
Jane Morbey Road  
THAME, OXON OX9 3RR

+44 (0)1844 215200  
enquiries@pohlcon.co.uk

[www.pohlcon.co.uk](http://www.pohlcon.co.uk)

© PohlCon | PC-LIT-TI-JTA-SD-EN | 06-2025 | 1st v. | 06 -2025